

MANUFACTURERS TAB DATA	
MODEL	10'x10'x8' MANHOLE BOX (MHB)
MODEL NO.	MHB-08103
MHB HEIGHT (FT)	8
MHB LENGTH (FT)	10
MHB THICKNESS (IN)	3
MAXIMUM DEFLECTION (IN)	1.08
MHB WEIGHT (LBS)	6631

ALLOWABLE DEPTH (FT)			
OSHA DEFINED SOILS TYPE			
DEPTH "D"			
A - 25	B - 45	C - 60	C - 80
40	33	25	19
SHIELD RATING (PSF)			1490

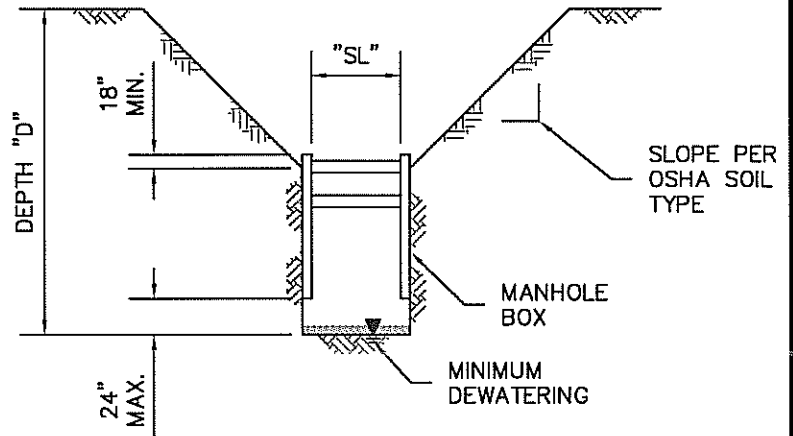

SIGNATURE DATE:
MAY 09 2018

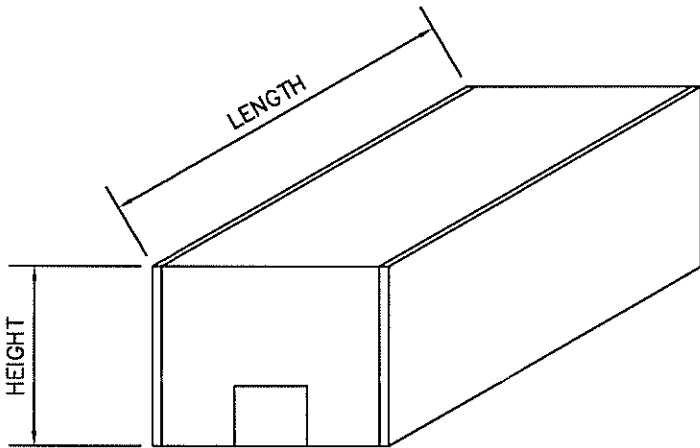

GENERAL NOTES:

1. THE EXCAVATION SHALL BE IN ACCORDANCE WITH OSHA CFR 29, PART 1926, SUBPART P DATED JULY 1997, AND CAL-OSHA SAFETY ORDERS TITLE 8 (SECTION 1504, AND 1539 THRU 1547). THIS TABULATED DATA HAS BEEN PREPARED BY A REGISTERED PROFESSIONAL ENGINEER AS REQUIRED TO COMPLY WITH THE ABOVE MENTIONED STANDARDS.
2. MANHOLE BOX MAY BE HELD OFF OF BOTTOM OF EXCAVATION NO MORE THAN 24" FOR SQUARE CUT TRENCH BOTTOM AND 36" FOR ROUND CUT TRENCH BOTTOM.
3. MANHOLE BOXES MAY BE STACKED (WITH APPROPRIATE STACKING PINS), SET VERTICAL OR UPSIDE DOWN.
4. OSHA DEFINED "COMPETENT PERSON" TO INSPECT MANHOLE BOX PRIOR TO USE TO VERIFY MANHOLE BOX IS IN GOOD WORKING CONDITION WITH NO SUBSTANTIAL DAMAGE OR DEFORMATION.
5. REPAIRS OR MODIFICATIONS TO THIS MANHOLE BOX MUST BE APPROVED BY THE MANUFACTURER AND/OR REGISTERED CIVIL ENGINEER IN WRITING.
6. AN OSHA DEFINED "COMPETENT PERSON" MUST CLASSIFY THE SOIL IN ACCORDANCE WITH OSHA (APPENDIX A) PRIOR TO PLACING THIS EQUIPMENT INTO THE EXCAVATION. THEY MUST BE TRAINED AND EXPERIENCED IN THE PROPER USE OF MANHOLE BOX, SAFE EXCAVATION PRACTICES, AND SOIL CLASSIFICATION METHODS. THEY SHALL DIRECT AND CONTROL THE USE OF THIS MANHOLE BOX. THEY ALSO MUST MONITOR THE EXCAVATION TO ENSURE THAT CONDITIONS HAVE NOT CHANGED FROM THE ORIGINAL SOIL CLASSIFICATION. IF CONDITIONS DO CHANGE, THEY ARE TO TAKE THE APPROPRIATE ACTION TO MAKE CERTAIN THAT THE MANHOLE BOX CAPACITY IS NOT EXCEEDED.
7. THE ALLOWABLE DEPTHS LISTED ABOVE TAKE INTO CONSIDERATION A SURCHARGE FROM TYPICAL LIGHT TRAFFIC AND CONSTRUCTION EQUIPMENT AS DEFINED IN THE CAL-TRANS TRENCHING AND SHORING MANUAL (72 PSF). THESE SURCHARGE LOADS ARE ASSUMED TO BE SETBACK A MINIMUM OF 2 FEET FROM EDGE OF THE EXCAVATION. IF LARGER MAGNITUDE SURCHARGES WILL BE PRESENT, THE MAXIMUM ALLOWABLE DEPTH OR MAXIMUM LOADING ON THE MANHOLE BOX IS TO BE DETERMINED BY A REGISTERED CIVIL ENGINEER.
8. THE MANHOLE BOX(S) SHOULD BE BACKFILLED WITH SOIL BETWEEN MANHOLE BOX(S) AND EXCAVATION TO KEEP MANHOLE BOX(S) IN PLACE AS DETERMINED IN THE FIELD BY THE COMPETENT PERSON. MANHOLE BOX(S) SHOULD BE PLACED BY WORKERS OUTSIDE THE EXCAVATION.
9. MANHOLE BOX MUST BE FULLY ASSEMBLED BEFORE PLACING INSIDE THE EXCAVATION.



Know what's below.
Call 811 before you dig.

SHEET TITLE
MANUFACTURES TABULATED
DATA SHEET

B.K. WELLINGTON
Engineering, Inc.

122 CALISTOGA ROAD #501 - SANTA ROSA, CA 95409
PH: (707) 585-5423

10 x 10 x 8' TALL
MANHOLE BOX

MANUFACTURES TABULATED DATA
MODEL NO: MHB-08103

SACRAMENTO
Shoring Supply

2175 ACOMA STREET
SACRAMENTO, CA 95815

SHEET NO.
TD1.0
1 OF 2

DATE
05/03/18

DRAWN
BKW

DWG NO.
18.145-05

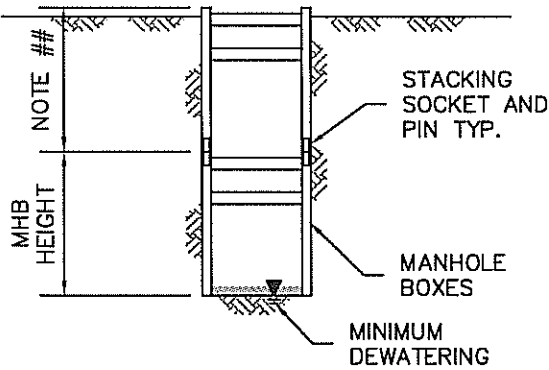

NOTE ##: STACKER
MANHOLE BOXES VARIES
FROM 2 FT TO 10 FT IN
HEIGHT



SIGNATURE DATE:
MAY 09 2018

1

SECTION

FLAT BOTTOM WITH
STACK SHIELDS

Scale: NTS

NOTE ###: 3 FT
MINIMUM BENCH

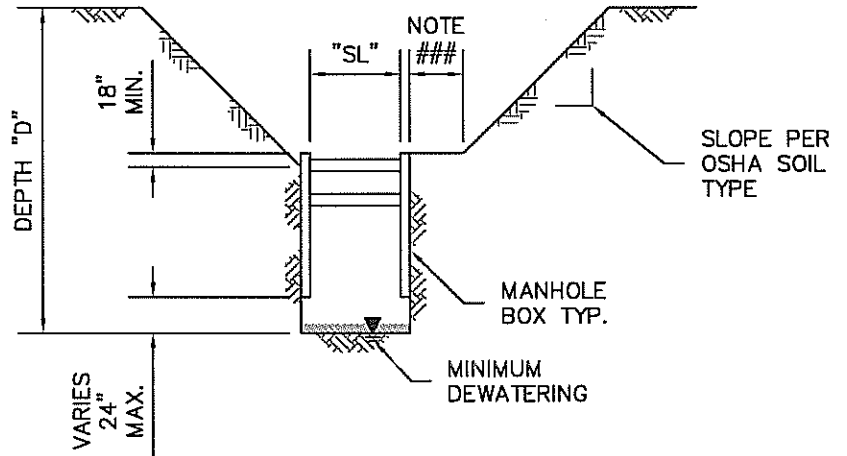

2

SECTION

FLAT BOTTOM CROSS
SECTION

Scale: NTS

NOTE ###: 3 FT
MINIMUM BENCH

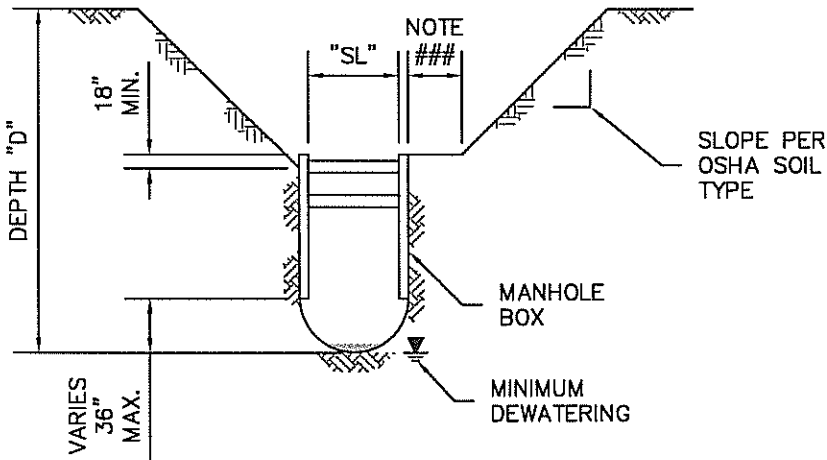

3

SECTION

ROUND BOTTOM CROSS
SECTION

Scale: NTS



Know what's below.
Call 811 before you dig.

SHEET TITLE
MANUFACTURES TABULATED
DATA SHEET

B.K. WELLINGTON
Engineering, Inc.

122 CALISTOGA ROAD #811 - SANTA ROSA, CA 95409
PH: (707) 595-5423

10 x 10 x 8' TALL
MANHOLE BOX

MANUFACTURES TABULATED DATA
MODEL NO: MHB-08103

SACRAMENTO
Shoring Supply

2175 ACOMA STREET
SACRAMENTO, CA 95815

SHEET NO.
TD2.0
2 OF 2

DATE
05/03/18

DRAWN
BKW

JOB NO.
18.145-05